



500 LB



OUR CARTS  
HAUL  
MORE

PROUDLY  
MADE IN THE  
USA



BUILT  
HEAVY DUTY  
TO OUTLAST  
OTHERS



THREE  
YEAR  
LIMITED  
WARRANTY

## FEATURES

- Designed specifically for the Mantis, but can also be used with the Multi Mover, Multi Mover XT, or Fork Hand Truck
- 3" Casters, 2 fixed, 2 swivel
- Mantis forks slide into built in guides
- E-Track ratchet system, 12' E-Strap sold separately (PI-11-0212)
- Holds up to 50 chairs
- 500 lb capacity

## STANDARD AMERICAN CART FEATURES

- **Made in the USA**  
Hand crafted at our Ohio plant.
- **Heavy-duty comes standard**  
American Carts are all built to heavy duty specs
- **Powder coated finish**  
Protects the steel and provides a lasting finish
- **Steel construction**  
Built from American sourced steel
- **Easy to operate**  
Designed to get work done with less muscle strain and simple operation.
- **Ready to ship**  
in stock and ready to ship
- **Three Year Limited Warranty**



Shown with 25 wooden folding chairs.

# AMERICAN CART & RACK

MANUFACTURED BY GRANITE INDUSTRIES

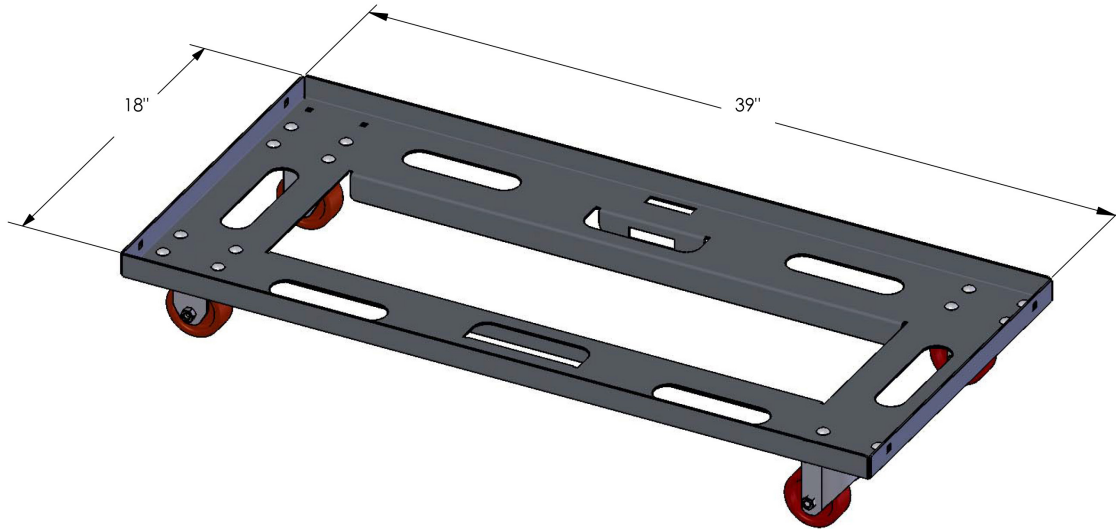

---

**Dimensions:**    **W:** 18"    **D:** 39"    **H:** 6"

---

**Weight:**        20 lbs.        **Capacity:**    500 lbs.

---

**Typically Ships:**    UPS; minimal assembly required

---