



GRANITE
INDUSTRIES

A M E R I C A N
C A R T & R A C K

MANUFACTURED BY GRANITE INDUSTRIES

TITAN II APPLIANCE CART

INSTRUCTION MANUAL



67101-75

CONTENTS

Specs	3
Parts Diagram	4
Setup	5

TOOLS NEEDED

- Box Cutters / Utility Knife

MADE IN THE USA GUARANTEE



Our American made products are engineered, manufactured and assembled in Archbold, OH using USA made steel.



Expect more. get more.
FROM GRANITE INDUSTRIES

- Exceptional quality and service on every single product.
- Professional grade designs by our in house engineers.
- Industry leading warranties.
- Family owned and operated in the USA.

To view more products from
American Cart & Rack
scan the QR code with your phone
or visit AmericanCartAndRack.com



WARRANTY

3 Year Limited Warranty. Carts, excluding any finishes, casters and wheels are warranted for three (3) years from date of original purchase. Casters and wheels are warranted for 90 days from date of original purchase. We will repair, without charge, any defect due to faulty material or workmanship. These warranties do not cover failures due to abuse, misuse, improper installation, accidental damage or when repairs or modifications have been made or attempted to be made by anyone other than Granite Industries. Any defective products that meet warranty specifications and Granite Industries approval, may be returned to the factory to be repaired or replaced free of charge. (Granite Industries will pay to ship replacement item(s) to the customer; however the customer is responsible for shipment of products to the factory.) This remedy is the sole remedy in contract, tort or otherwise, and Granite Industries is not liable for incidental, consequential or special damages. These warranties give you specific legal rights, and you may have other rights which vary from state to state. Should you have any questions, contact Granite Industries (Proof of purchase may be required).



**GRANITE
INDUSTRIES**

**Customer Service
877-447-2648
M-F, 8am - 5pm EST**

SPECS

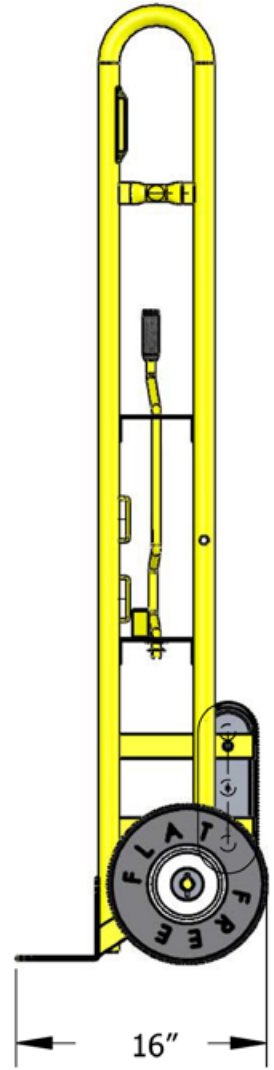
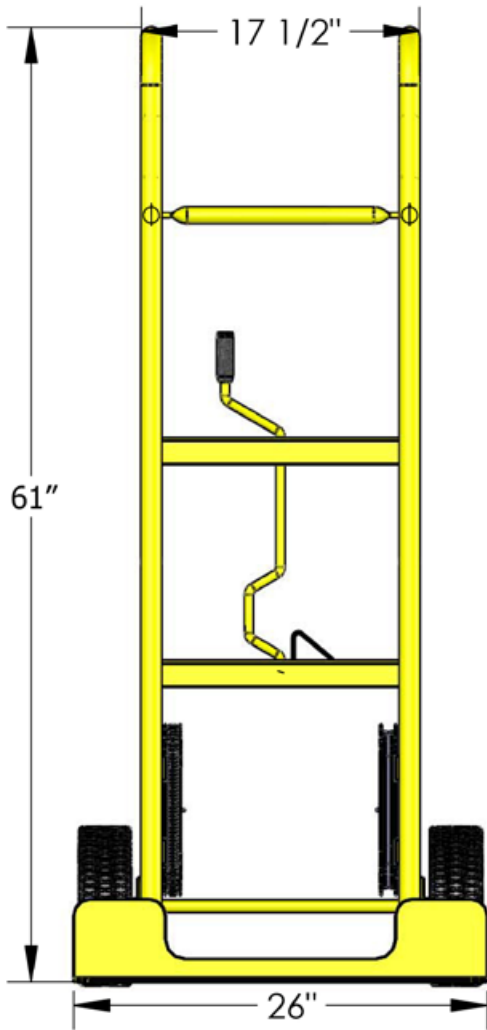

Overall Dimensions:	W: 26"	D: 16"	H: 61"
Foot Plate:	W: 26"	D: 5"	
Weight:	70 lbs.	Capacity:	600 lbs.

PARTS DIAGRAM

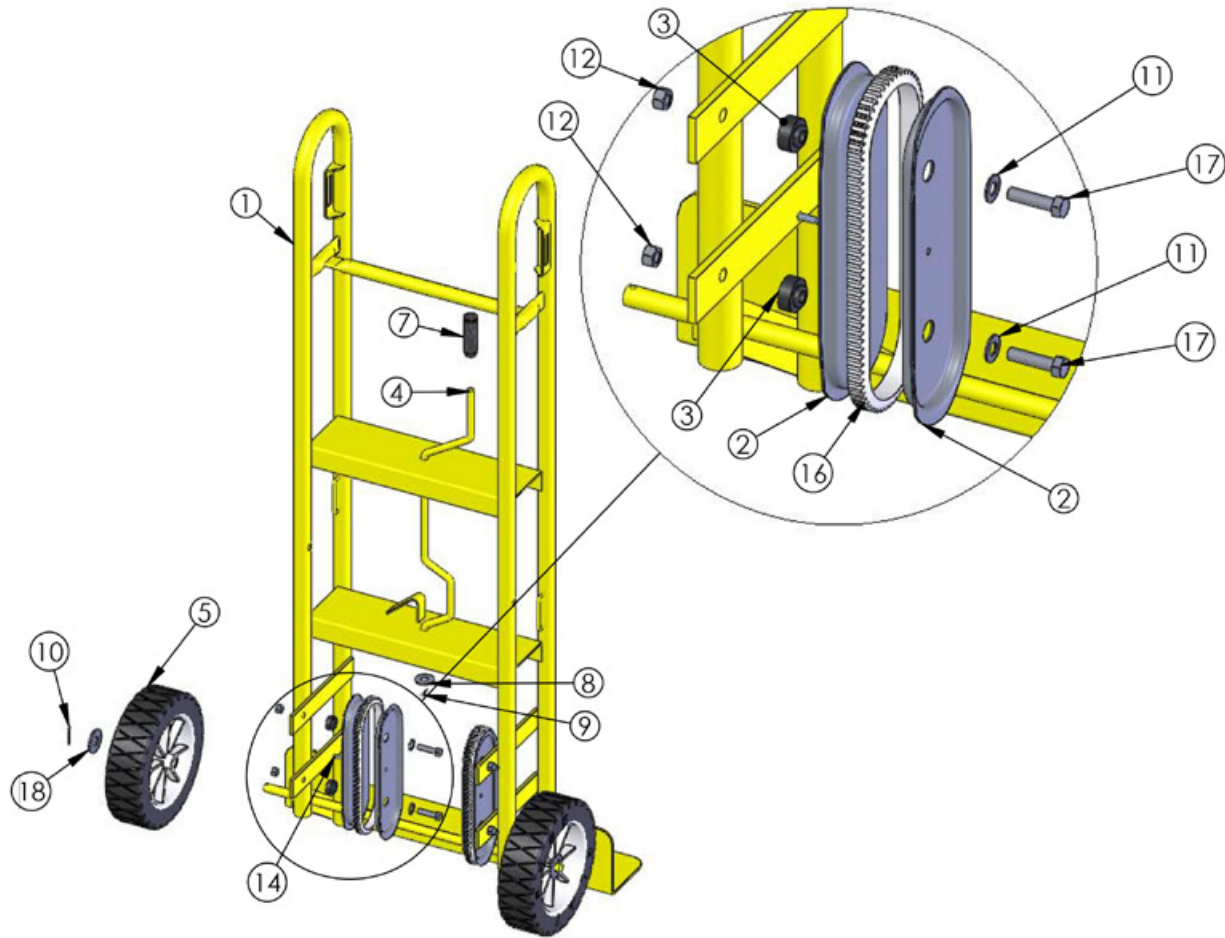

ITEM NO	QTY	PART NO	DESCRIPTION
1	1	MI-12-2009	CART 67101
2	4	MI-08-0543	Track for rubber belt
3	4	MI-15-0015	Bushing - 25/64" ID x 1"
4	1	MI-04-0121	Crank
5	2	PI-06-0032	10" Flat free offset wheel
6	1	PI-11-0016	Strap
7	1	PI-04-0115	Rubber cap for crank handle
8	1	PI-01-0002	1/2" Washer
9	1	PI-01-0073	Cotter Pin - 5/32" x 3/4"
10	2	PI-01-0226	Cotter Pin 1/8" x 1-1/4"
11	4	PI-01-0030	3/8" Washer
12	4	PI-01-0019	3/8" Locknut
14	2	PI-01-0140	Pop Rivet 3/16"
16	2	PI-11-0018	Rubber Belt
17	4	PI-01-0028	Hex Bolt 3/8"-16 x 1-1/2"
18	2	PI-01-0032	5/8" Washer

TIE STRAP SETUP



1

Lift the center roller.



2

Slide the strap under the center roller.



3

Lower the center roller and insert the strap back through, this time going above the roller.



4

Your strap should now lock in place when tightened.



GRANITE INDUSTRIES
595 EAST LUGBILL ROAD
877-447-2648
SUPPORT@GRANITEIND.COM