

# AMERICAN CART & RACK

MANUFACTURED BY GRANITE INDUSTRIES

67416  
ALUMINUM DUAL WHEELED  
APPLIANCE CART W/ REAR WHEELS



1,200 LB



OUR CARTS  
HAUL  
MORE

PROUDLY  
MADE IN THE  
USA



BUILT  
HEAVY DUTY  
TO OUTLAST  
OTHERS



THREE  
YEAR  
LIMITED  
WARRANTY

## FEATURES

- 3/4" axle
- Dual 10" flat free dual wheels with high capacity plastic hubs
- Adjustable rear 4" casters
- D-brackets on axle add more stability and strength
- Powder coated steel handle
- Dual integrated 10' auto retracting ratchet straps (2" x 10')
- Rubber bumpers protect your load from scratches
- Dual steel stair-crawlers
- Aluminum construction

## STANDARD AMERICAN CART FEATURES

- **Made in the USA**  
Hand crafted at our Ohio plant.
- **Heavy-duty comes standard**  
American Carts are all built to heavy duty specs
- **Aluminum Construction**  
Light weight and durable
- **D-Brackets**  
One piece design supports the axle and load better than the competition
- **3/4" Axle**  
Industry leading axle size for maximum strength.
- **Easy to operate**  
Designed to get work done with less muscle strain and simple operation.
- **Ready to ship**  
in stock and ready to ship
- **Three Year Limited Warranty**

**RAPTOR**  
HIGH PERFORMANCE ALUMINUM PRODUCTS



10'L x 2"W auto retracting ratchet strap.

# AMERICAN CART & RACK

MANUFACTURED BY GRANITE INDUSTRIES

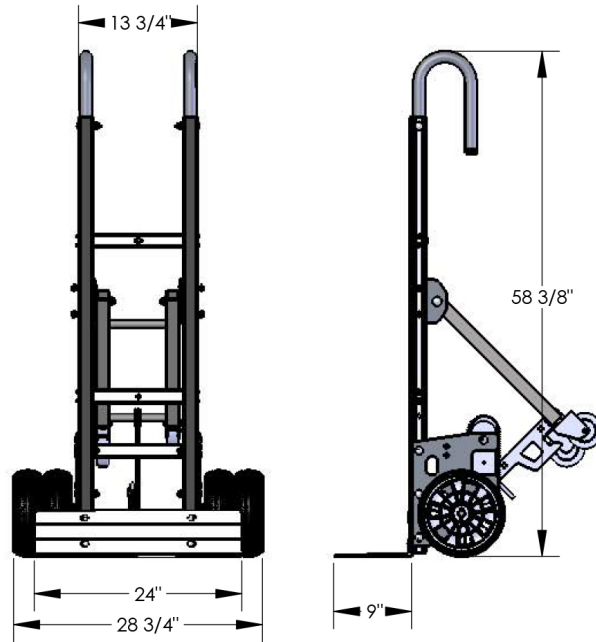

<b>Dimensions:</b>	<b>W:</b> 28.5"	<b>D:</b> 52"	<b>H:</b> 45"
<b>Foot Plate:</b>	<b>W:</b> 24"	<b>D:</b> 9"	
<b>Weight:</b>	68 lb	<b>Capacity:</b>	1,200 lb
<b>Typically Ships:</b>	UPS, some assembly required		

\*Measurements taken while cart is on 6 wheels